

MFS flow sensor for measurement of velocity or flow of air and other gases

Datasheet:md-1313gb/2018-12-03
Replace:md-1313gb_060626

MFS

- ✓ High accuracy
 - ✓ High differential pressure
 - ✓ Low pressure drop
 - ✓ Standard and special dimensions
 - ✓ Patented construction
 - ✓ Possibility to get additional environmental protective Epoxy coating
 - ✓ MFS is also available in Acid-proof stainless steel construction with maximum length of 1600 mm.
- [See separate data sheet Md-1303]

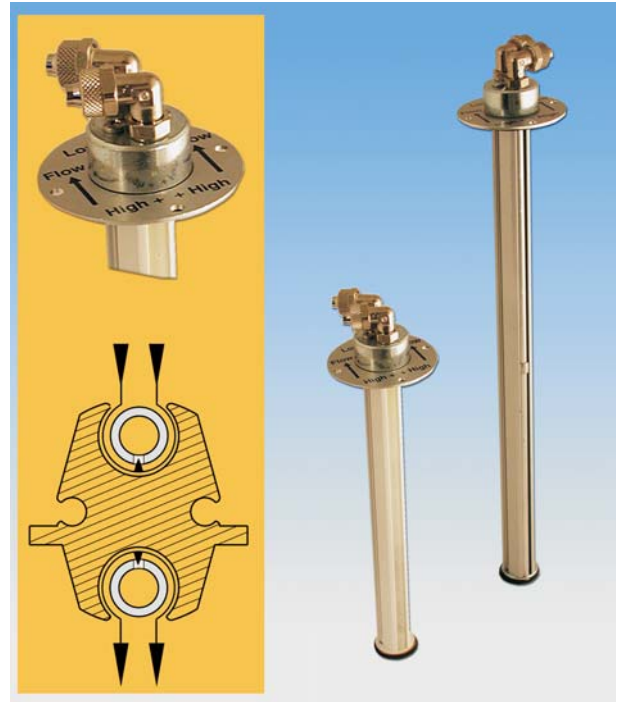

Application

Micatrone flow sensor MFS is developed to meet the great demand for accurate air flow measurement in all types of air handling systems.

MFS forms an average of the velocity profile of the complete channel area. MFS measures the total pressure ($p+$) as well as the amplified flow influenced pressure ($p-$).

Together these both, $p+$ and $p-$, form a differential pressure from which the flow/velocity are possible to calculate.

This differential pressure is 2,5 times higher than the corresponding acquired by Prandtl measurements.

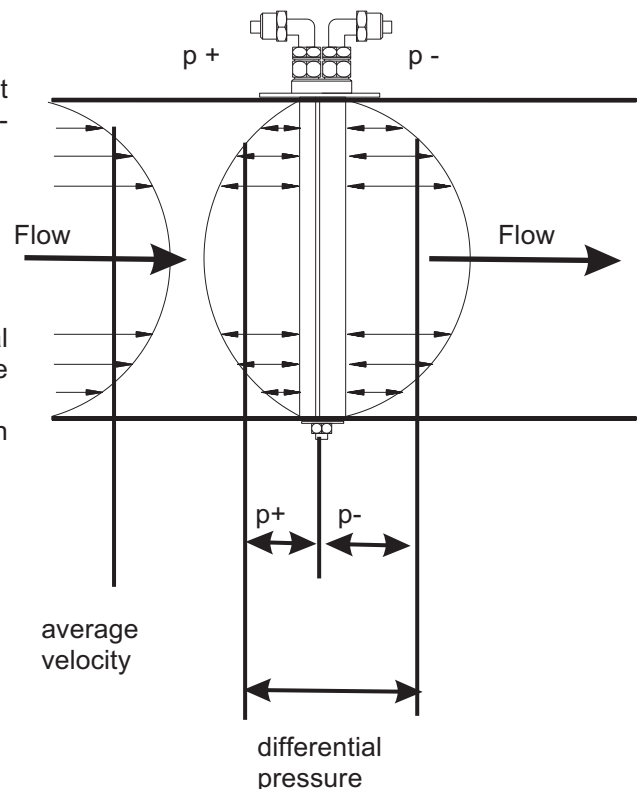

Construction

The flow sensor consists of a solid bracket, which is made of extruded, anodised aluminium in which two measuring pipes follow the whole length. The measuring pipes are complete protected by the solid bracket.

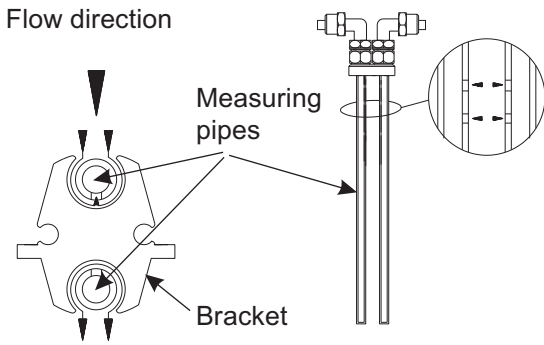

The measuring pipes are holed in accordance with reliable standards. The holes face towards the centre of the bracket.

An air gap surrounds the measuring pipes. The advantage with this construction is that the holes of the measuring pipes are at a point where there is no velocity, which prevent particles from entering the pipes.

The measured pressure is by this construction very stable.

The stable construction of MFS enables sensor lengths up to 2500 mm.

MFS is available as standard in all standard duct sizes and in special versions with dimensions from 80 to 2500 mm.

Each sensor is provided with a label showing the flow constant K_m and formulas for the calculation of velocity and flow.

Epoxypainted sensors with measuring pipes of polyethene

When there is need of extra protection against corrosion there is an epoxypainted version of MFS with measuring pipes of polyethene.

The epoxypainted version has, of construction reasons, the holes turned towards the flow direction. Beside this there are the same specifications as for the MFS standard.

The flow constant

The flow constant is determined both by an advanced computer programme and by empirical tests. The flow constant has a measurement error of $<\pm 2\%$ of the actual undisturbed flow.

The flow constant is linear within the range of 2...25 m/sec.

The total measurement error in the system is affected by where it is mounted and the number of sensors in comparison with the duct size. By following our recommendations the measurement error normally is $<\pm 3...5\%$ of the actual flow.

The number of sensors

The following recommendations concern circular and rectangular ducts:

Circular ducts

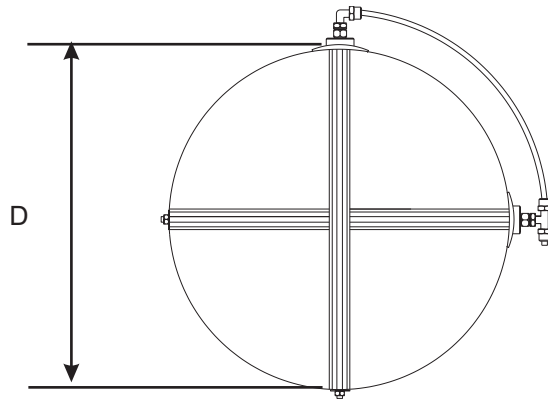

Diameter mm	Number of sensors
$80 \leq D < 400$	1
$400 \leq D < 900$	2
$900 \leq D < 1500$	3

Rectangular ducts

The length should be selected to suit the longest side of the duct (L).

The number of sensors according to the width (W) of the duct.

Width mm	Number of sensors
$100 \leq W < 400$	1
$400 \leq W < 600$	2
$600 \leq W < 900$	3
$900 \leq W < 2500$	4

Calculation of flow and velocity

The following simplified formulas applies for air at 20 °C and 1013 mbar.

For other air temperatures and barometric pressures a correction must be calculated due to change in density.

$$v = K_m \times \sqrt{\Delta p} \text{ (m/s)}$$

$$Q = A \times K_m \times \sqrt{\Delta p} \text{ (m}^3\text{/s)}$$

v = velocity (m/s)

K_m = the flow constant

Δp = differential pressure (Pa)

A = channel area (m²)

Q = flow (m³/s)

ρ = air density (kg/m³)

B = actual barometric pressure (mbar)

t = actual temperature (°C)

Correction for temperature or barometric pressure

$$\rho = 1293 \times \frac{B}{1013} \times \frac{273}{273+t} \left(\frac{\text{kg}}{\text{m}^3} \right)$$

$$Q = A \times K_m \sqrt{\Delta p \frac{12}{\rho}} \left(\frac{\text{m}^3}{\text{s}} \right)$$

Flow constant K_m circular duct

Diam	Blockage	K_m
100	0,276	0,771
125	0,221	0,792
150	0,184	0,805
160	0,173	0,810
200	0,138	0,823
250	0,110	0,833
315	0,088	0,841
400	0,069	0,848
500	0,055	0,852
600	0,046	0,856
630	0,044	0,856
800	0,035	0,860
1000	0,028	0,862
1250	0,022	0,864

Flow constant K_m rectangular duct

Width	Blockage	K_m
100	0,22	0,793
150	0,145	0,820
200	0,109	0,833
250	0,087	0,841
300	0,072	0,846
400	0,054	0,853
500	0,043	0,857
600	0,036	0,859
700	0,031	0,861
800	0,027	0,862
900	0,024	0,863
1000	0,022	0,864
1200	0,018	0,866
1400	0,016	0,866
1600	0,014	0,867
1800	0,012	0,868
2000	0,011	0,868

Lasting pressure drop in the duct

The flow sensor causes a low pressure loss in the duct system. The pressure loss is calculated by the following formula:

Pressure loss (Pa) = blockage x number of sensors x differential pressure (Pa)

The blockage is stated in the table for flow constant.

Example:

- Circular duct 315 mm with 1 sensor
- Velocity 5 m/s
- Blockage 0,088
- Differential pressure 35 Pa

$$\text{Pressure loss} = 0,088 \times 1 \times 35 = 3,08 \text{ Pa}$$

Selection of mounting place

To achieve the best measuring result it is important that the flow sensor is mounted where it is possible to get the most undisturbed flow as possible.

In the flow direction before a flow sensor it is recommended with a straight part of the duct 5-7 times the length of the sensor and after 1 time the length of the sensor.

The flow sensor shall be mounted before a damper in the flow direction approx. 1 time the length. After a damper not closer than 7-10 times the length of the sensor.

Installation

The sensor is fastened in the duct with 4 pcs of self-tapping screws at the top end and in the bottom with 1 pcs M6 nut.

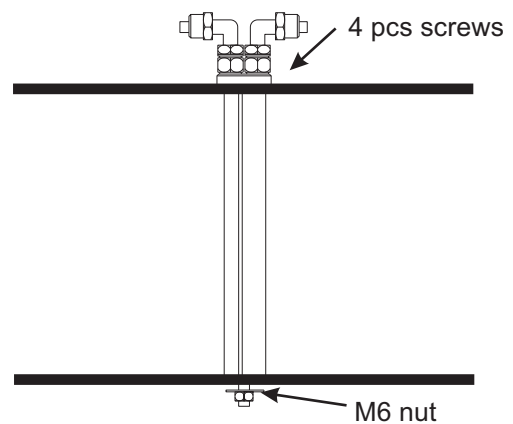

Connection of sensors in parallel

Replace the revolving angular pipe fitting by a T-shaped pipe fitting according to the picture. Connection sets are available for 2, 3 or 4 sensors.



The Flow transmitters

Micatrone flow transmitter serie MicaFlex are suitable for use together with MFS.

The MicaFlex serie includes flow linearisation and measures the differential pressure, which comes from the flow sensor.

The following units from the MicaFlex serie shows the flow on a display and gives a flow linear output; MF-FD/PFT/PFC/PFA/PFCA and PFCP.

All flow transmitters, except to MF-FD, include a controller which is suitable for flow control.

For more information, see respective datasheet.

Pressure range flow transmitter

The pressure range for the flow transmitter is selected in view of the max velocity in the duct and calculated with the formula for flow linear output.

Following approx. values are achieved for K_m 0,85:

Pressure range		Velocity (m/s)	
Min	Max	Min	Max
0 (5)*...100 Pa		2,0...	8,5
0 (10)*...200 Pa		2,5...	12,0
0 (25)*...500 Pa		4,0..	19,0
0 (50)*...1000 Pa		5,0...	27,0

* Min.level flow measurement

Material

Material, part	Standard	Epoxy-painted
Bracket	Anodised aluminium	Epoxypainted anodised aluminium
Measuring pipes	Aluminium	Polyethene
Bottom attachment	Chromed steel	Epoxypainted chromed steel
Anchor plate	Anodised aluminium	See standard
Pressure connections	Nickel-coated brass for HT-plastic tubing 8/6	See standard
Sealings	Expanded rubber	See standard

Specifications

Measure range	2...25 m/s
Max. temperature	80 °C
Measurement error	< ± 3...5%
Max. static pressure	100 kPa

Ordering codes

MFS-C circular duct		MFS-R rectangular duct	
Diameter	MFS-	Length	MFS-
100	C-100	100	R-100
125	C-125	150	R-150
150	C-150	200	R-200
160	C-160	250	R-250
200	C-200	300	R-300
250	C-250	400	R-400
315	C-315	500	R-500
400	C-400	600	R-600
500	C-500	700	R-700
600	C-600	800	R-800
630	C-630	900	R-900
800	C-800	1000	R-1000
1000	C-1000	1200	R-1200
1250	C-1250	1400	R-1400
Special	C-.... mm	1600	R-1600
		1800	R-1800
		2000	R-2000
		Special	R-... mm

Example

Standard Flow measuring sensor length 400 mm for rectangular duct: **MFS-R-400**

Increased temperature

MFS standard are possible to order for two higher temperatures: max 150 °C and 400 °C.

Accessories:

MTS-F2 connection kit 2 pcs MFS
 MTS-F3 -"- -"- 3 pcs MFS
 MTS-F4 -"- -"- 4 pcs MFS

Cleaning of MFS with compressed air

In difficult applications where there is a risk for particles to enter the measuring pipes, automatic cleaning with compressed air is used. Contact Micatrone for more information.