

**FEATURES**

- Field Bus data acquisition
- CAN open protocol
- Baud rate and ID Node programmable by dip-switch
- 16 digital inputs
- Led of signalling for inputs status
- Four ways 2000 Vac galvanic isolation
- EMC compliance – CE Mark
- In compliance to EN-50022 DIN rail mounting



**GENERAL DESCRIPTION**

The device DAT 7148 is able to acquire up to 16 digital inputs. The data are transmitted by the CANopen protocol. The 2000 Vac galvanic isolation between inputs, power supply and data line eliminates the effects of all ground loops eventually existing and allows the use of the device in heavy environmental conditions found in industrial applications. The DAT 7148 is housed in a rough self-extinguishing plastic enclosure of 22.5 mm thickness, suitable for DIN rail mounting in compliance with the EN 50022 standard .

**COMMUNICATION PROTOCOLS**

On the DAT7000 modules are implemented the following communication protocols:

CANopen Protocol: one of the most used standard communication protocol; it allows to interface the modules of DAT7000 series directly to the CAN Controllers that accept devices in compliance with the **CiA DS 301** and **CiA DS 401** standards. For communication setting, refer to the User manual.

**OPERATING INSTRUCTIONS**

Before to install the device, please read carefully the "Installation instructions" section. Connect the power supply, the data line and the input signals as shown in the "Wiring" section. Refer to the "Led signalling" section to verify the correct working of the device. To make easy the maintenance or the substitution of the device, it is possible the "hot swap" of the terminals.

**INSTALLATION INSTRUCTIONS**

The device DAT 7148 is suitable to be mounted on DIN rail, in vertical position. For a correct working and a long life of the device, read the following indications. **In case of the devices are mounted side by side, please leave about 5mm between in the following situations:**

- Temperature in the cabinet higher than 45 °C and high supply voltage ( >27Vdc ).

Avoid to place raceways or other objects which could obstruct the ventilation slits. It is suggested to avoid that devices are mounted above appliances generating heat; their ideal place should be in the lower part of the panel. Avoid to install the devices in a site where vibrations are present. It is recommended to use shielded cable for connecting signals. The shield must be connected to an earth wire provided for this purpose. Moreover it is suggested to avoid routing conductors near power signal cables.

**TECHNICAL SPECIFICATIONS (Typical @ 25 °C and under nominal conditions)**

<b>Device profile</b>  In compliance with the <b>CiA DS 301</b> and <b>CiA DS 401</b> standard.	<b>Digital Inputs</b> Channels 16 Input voltage (bipolar) OFF State 0 ÷ 3 V ON State 10 ÷ 30 V N° of counters 8 @ 300 Hz Min. Pulse width 1 ms  Impedance 4.7 KΩ	<b>Power supply</b> Supply Voltage 10 .. 30 Vdc Current consumption 45 mA @ 24 Vdc Reverse Polarity protection 60 Vdc max  <b>Isolation Voltage</b>  2000 Vac 50 Hz, 1 min. (Inputs/Can Network/Power supply)
	<b>Sample time</b> 5 ms <b>Data Transmission</b> Baud rate up to 1 Mbps Max. Distance in function of the Baud rate	<b>Environmental Conditions</b> Operative Temperature -10°C .. +60°C Storage Temperature -40°C.. +85°C Humidity (not condensed) 0 .. 90 % Maximum Altitude 2000 m Installation Indoor Category of installation II Pollution Degree 2
<b>Mechanical specifications</b> Material Self-extinguish plastic IP Code IP20 Wiring wires with diameter 0.8÷2.1 mm <sup>2</sup> /AWG 14-18  Tightening Torque 0.8 N m Mounting in compliance with DIN rail standard EN-50022 Weight about 150 g.		<b>EMC ( for industrial environments )</b> Immunity EN 61000-6-2 Emission EN 61000-6-4

## CABLING

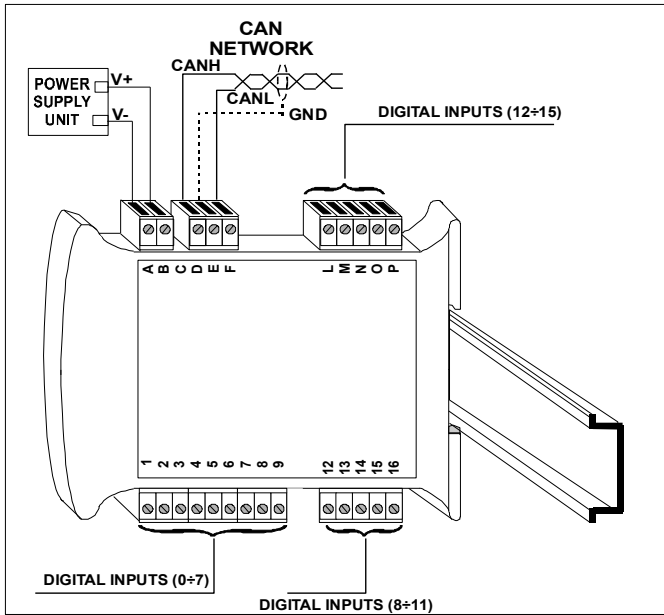

## DIP SWITCH POSITION

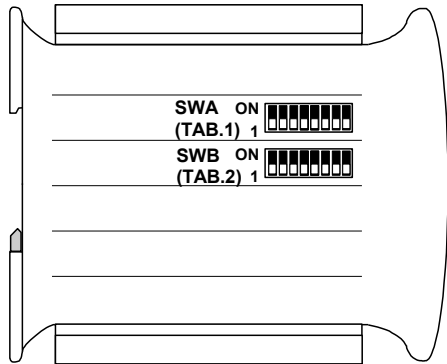

## DIP-SWITCH CONFIGURATION TABLES

TAB.1 Address setting 1÷127  
(Pos.1 LSB; Pos.7 MSB)

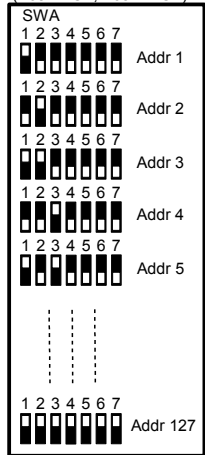

TAB.2 Bit rate setting  
(Pos.5 LSB; Pos.8 MSB)

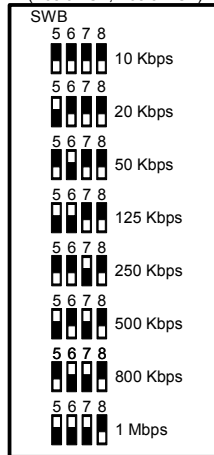

## MECHANICAL DIMENSIONS (mm)

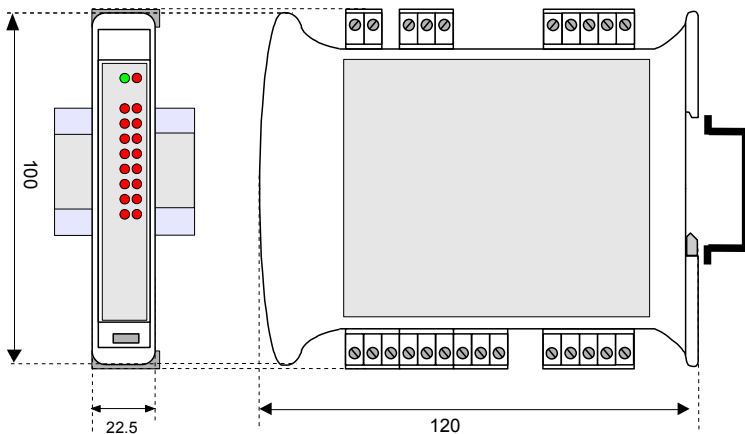

## WIRING

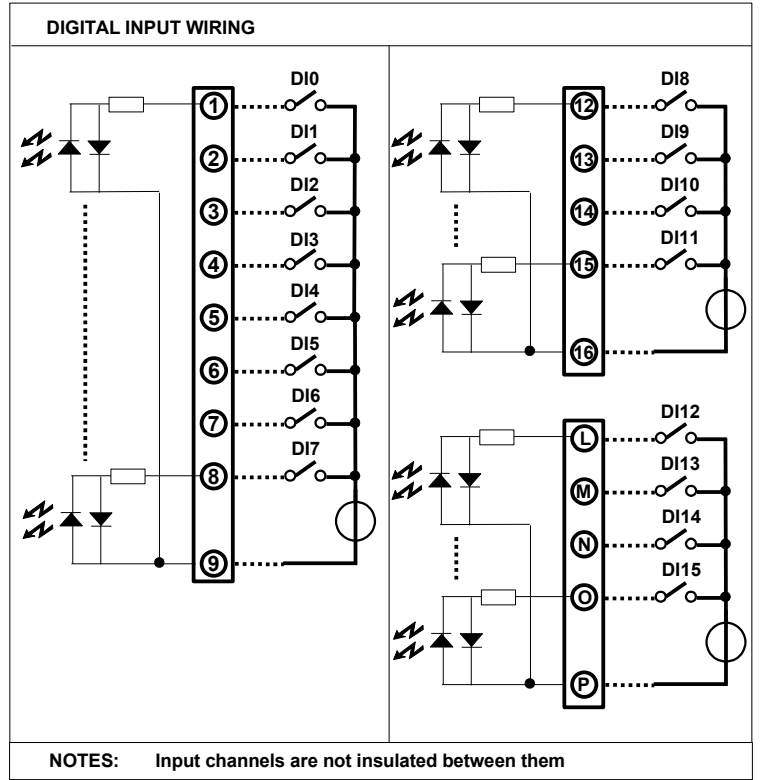

NOTES: Input channels are not insulated between them

## POWER SUPPLY WIRING

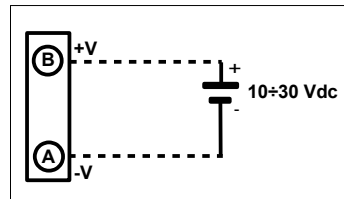

## CAN NETWORK WIRING

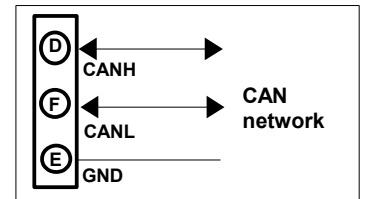

## ISOLATION STRUCTURE

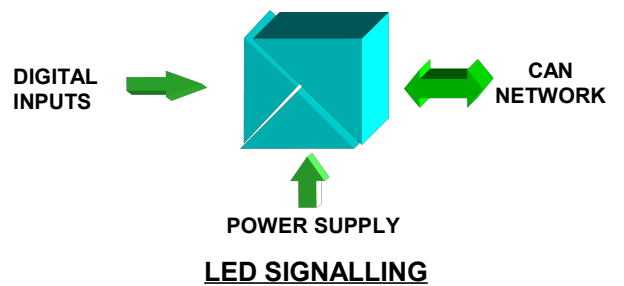

LED	COLOR	STATE	DESCRIPTION
RUN	GREEN	ON	Device in Operational mode
		BLINKING	Device in Pre-Operational mode
		SLOW BLINKING	Device stopped
ERR	RED	OFF	No error
		ON	Bus off
		BLINKING	Invalid configuration
In	RED	ON	State 1 Digital Inputs.
		OFF	State 0 Digital Inputs.

**HOW TO ORDER**  
DAT 7148

The symbol reported on the product indicates that the product itself must not be considered as a domestic waste. It must be brought to the authorized recycle plant for the recycling of electrical and electronic waste. For more information contact the proper office in the user's city, the service for the waste treatment or the supplier from which the product has been purchased.