

Isolated converter for voltage and current configurable by Dip-Switch or PC **DAT 4531 D**

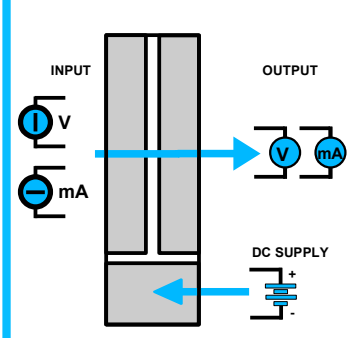

FEATURES

- Configurable input for voltage and current
- Configurable output in current or voltage
- Configurable by dip-switch or PC
- High accuracy
- On-field reconfigurable
- Galvanic isolation among the ways
- UL / CE mark
- Suitable for DIN rail mounting in compliance with EN-50022 and EN-50035



GENERAL DESCRIPTION

The isolated converter DAT 4531 D is able to measure voltage and current signals. In function of programming, the measured values are converted in a current or voltage signal. The device guarantees high accuracy and performances stability both versus time and temperature. The programming is made by the dip-switch located in the window on the side of the enclosure. By means of dip-switches it is possible to select the input type and range and the output type without recalibrate the device.

Moreover, by Personal Computer the user can program all of the device's parameters for his own necessity.

The terminals of the current signal on input side must be only connected to active current loop.

The 1500 Vac galvanic isolation on all ways (input, output and power supply) eliminates the effects of all ground loops eventually existing and allows the use of the converter in heavy environmental conditions found in industrial applications.

The DAT 4531 D is in compliance with the Directive UL 61010-1 for US market and with the Directive CSA C22.2 No 61010-1 for the Canadian market.

It is housed in a plastic enclosure of 12.5 mm thickness suitable for DIN rail mounting in compliance with EN-50022 and EN-50035 standards.

USER INSTRUCTIONS

The connections must be made as shown in the section "Connections".

It is possible to configure the converter on field by dip-switch or Personal Computer as shown in the section " Programming ". The configuration by dip-switches can be made also if the device is powered (note: after the configuration the device takes some seconds to provide the right output measure).

TECHNICAL SPECIFICATIONS (Typical at 25 °C and in nominal conditions)

INPUT				OUTPUT				POWER SUPPLY	
Input type	Min	Max	Min.Span	Output type	Min	Max	Min Span		
Voltage	0 V	10 V	1 V	Current	0 mA	20 mA	4 mA	Power supply voltage	18 .. 30 Vdc
Current	0 mA	20 mA	1 mA	Voltage	0 V	10 V	1 V	Reverse polarity protection	60 Vdc max
Accuracy (1)				Output resolution				Current consumption	
Volt	the higher of $\pm 0.1\%$ f.s. and ± 2 mV			Current	7 μ A			Current output	35 mA max.
mA	the higher of $\pm 0.1\%$ f.s. and ± 6 μ A			Voltage	4 mV			Voltage output	20 mA max.
Linearity (1)				Burn-out values				ISOLATION	
Volt, mA	$\pm 0.05\%$ f.s.			Max. output value	22 mA or 10.6 V			Among all the ways	1500 Vac, 50 Hz, 1 min
Input impedance				Output load Resistance - Rload				ENVIRONMENTAL CONDITIONS	
Voltage	≥ 1 M Ω			Current output	$< 500 \Omega$			Operative Temperature	-20°C .. +60°C
Current	$\leq 50 \Omega$			Voltage output	> 10 K Ω			UL Operative Temperature	-10°C .. +60°C
Thermal drift (1)				Response time (10+ 90%)				Storage Temperature	-40°C .. +85°C
Full scale	$\pm 0.01\%$ / °C			about 100 ms				Humidity (not condensed)	0 .. 90 %
								Maximum Altitude	2000 m
								Installation	Indoor
								Category of installation	II
								Pollution Degree	2
								MECHANICAL SPECIFICATIONS	
								Material	Self-extinguish plastic
								IP Code	IP20
								Wiring	wires with diameter 0.8+2.1 mm ² /AWG 14-18
								Tightening Torque	0.8 N m
								Mounting	in compliance with DIN rail standard EN-50022 and EN-50035
								Weight	about 90 g.
								CERTIFICATIONS	
								EMC (for industrial environments)	
								Immunity	EN 61000-6-2
								Emission	EN 61000-6-4
								UL	
								US Standard	UL 61010-1
								Canadian Standard	CSA C22.2 No 61010-1
								CCN	NRAQ/NRAQ7
								Typology	Open Type device
								Classification	Industrial Control Equipment
								File Number	E352854

(1)referred to the input Span (difference between max. and min.)

PROGRAMMING

CONFIGURATION BY DIP-SWITCHES

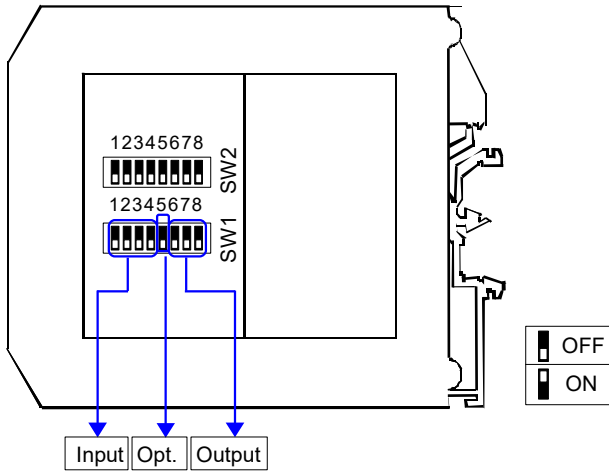

1) Open the suitable door on the side of the device.

Refer to TAB.1

2) Set the input type by the dip-switch SW1 [1..4]

3) Set the output type by the dip-switch SW1 [6..8]

4) Set the options by the dip-switch SW1 [5]

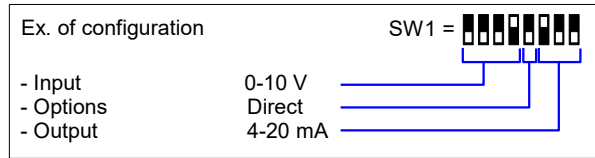

NOTE:

- It is also possible to set the dip-switches using the wizard of the configuration software following the procedure described in the section "Configuration by PC" until the step 6 and clicking on "Switch".

DIP-SWITCH CONFIGURATION TABLES

TAB.1 – Settings

Input	Output	Options
SW1 1 2 3 4	SW1 6 7 8	SW1 5
<input type="checkbox"/> <input type="checkbox"/> <input type="checkbox"/> <input type="checkbox"/> Default * <input type="checkbox"/> <input type="checkbox"/> <input type="checkbox"/> <input type="checkbox"/> 0÷20 mA <input type="checkbox"/> <input type="checkbox"/> <input type="checkbox"/> <input type="checkbox"/> 4÷20 mA <input type="checkbox"/> <input type="checkbox"/> <input type="checkbox"/> <input type="checkbox"/> 0÷10 V <input type="checkbox"/> <input type="checkbox"/> <input type="checkbox"/> <input type="checkbox"/> 2÷10 V <input type="checkbox"/> <input type="checkbox"/> <input type="checkbox"/> <input type="checkbox"/> 0÷5 V <input type="checkbox"/> <input type="checkbox"/> <input type="checkbox"/> <input type="checkbox"/> 1÷5 V	<input type="checkbox"/> <input type="checkbox"/> <input type="checkbox"/> 0÷20 mA <input type="checkbox"/> <input type="checkbox"/> <input type="checkbox"/> 4÷20 mA <input type="checkbox"/> <input type="checkbox"/> <input type="checkbox"/> 0÷10 V <input type="checkbox"/> <input type="checkbox"/> <input type="checkbox"/> 2÷10 V <input type="checkbox"/> <input type="checkbox"/> <input type="checkbox"/> 0÷5 V <input type="checkbox"/> <input type="checkbox"/> <input type="checkbox"/> 1÷5 V	Out: <input type="checkbox"/> Direct <input type="checkbox"/> Reverse

NOTES:

* If the dip-switches SW1 [1..4] are all set in the position 0 ("Default"), the device will follow the configuration programmed by PC (Input and output type and options).

* Eventual wrong dip-switches settings will be signalled by the blinking of the led "PWR".

CONFIGURATION BY PC

Notice: before to execute the next operations, check that the drivers of the cable CVPROG in use have been previously installed in the Personal Computer.

By software DATAPRO it is possible to:

- set the default programming of the device;
- program the options not available with the dip-switch; (burn-out level, CJC offset, trip alarm settings, delay on output, etc...);
- read, in real time, the input and output measures;
- follow the dip-switches configuration wizard.

To configure the device follow the next steps:

- 1) Open the protection plastic label on the front of the device.
- 2) Connect the two plugs of cable CVPROG to the Personal Computer (USB plug) and to the device (uUSB plug) .
- 3) Run the software
- 4) Select the COM port in use and click on "Open COM".
- 5) Select the device and connect to it.
- 6) Set the programming data.
- 7) Click "Write" to send the programming data to the device.

For information about the software refer to its user guide.

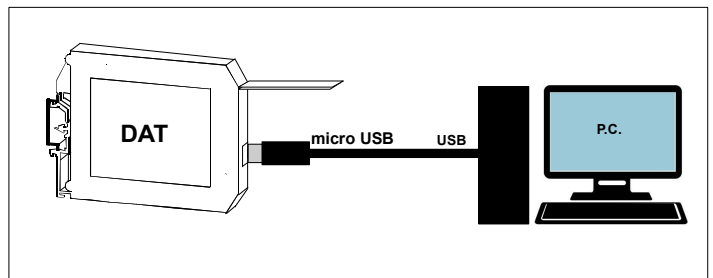

INSTALLATION INSTRUCTIONS

The device is suitable for fitting to DIN rails in the vertical position. For optimum operation and long life follow these instructions:

When the devices are installed side by side it may be necessary to separate them by at least 5 mm in the following cases:

- If panel temperature exceeds 45°C.
- Use of high power supply value (> 27 Vdc).
- Use of output current.

Make sure that sufficient air flow is provided for the device avoiding to place raceways or other objects which could obstruct the ventilation slits. Moreover it is suggested to avoid that devices are mounted above appliances generating heat; their ideal place should be in the lower part of the panel.

Install the device in a place without vibrations.

Moreover it is suggested to avoid routing conductors near power signal cables (motors, induction ovens, inverters etc...) and to use shielded cable for connecting signals.

ISOLATION STRUCTURE

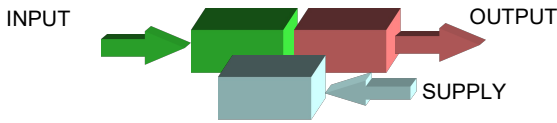

CONNECTIONS

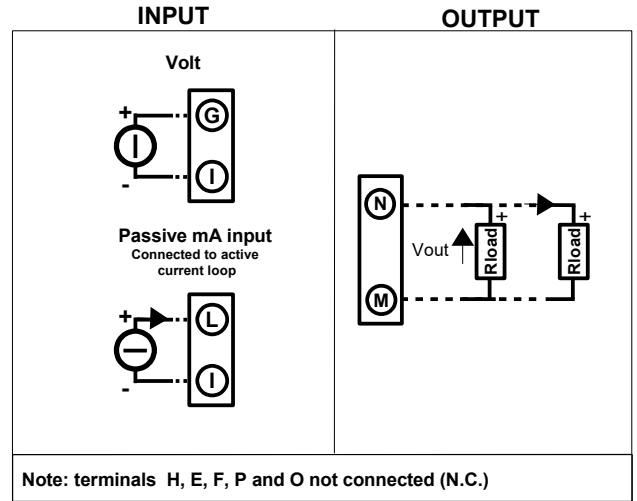

POWER SUPPLY(*)

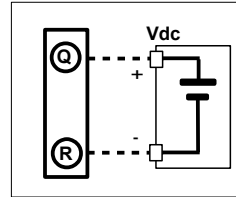

LIGHT SIGNALLING

LED	COLOUR	STATE	DESCRIPTION
PWR	GREEN	ON	Device powered
		OFF	Device not powered
		BLINKING	Wrong dip-switches setting

DIMENSIONS (mm)

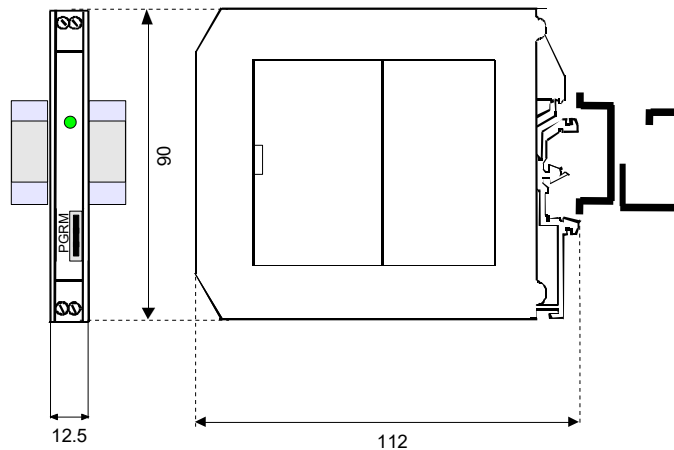

HOW TO ORDER

The device is provided as requested on the Customer's order. Refer to the section "Programming" to determine the input and output ranges. In case of the configuration is not specified, the parameters must be set by the user.

ORDER CODE EXAMPLE:

DAT 4531D / 4 ÷ 20 mA / 4 ÷ 20 mA / Direct

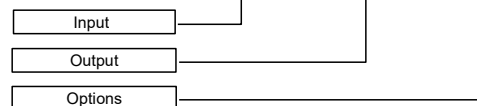

The symbol reported on the product indicates that the product itself must not be considered as a domestic waste. It must be brought to the authorized recycle plant for the recycling of electrical and electronic waste. For more information contact the proper office in the user's city, the service for the waste treatment or the supplier from which the product has been purchased.