

Fume Hood Sash Sensor for vertical sash

MSS-100

Application

The sensor is used to determine the position of the fume hood sash. The sensor consists of a precision potentiometer that is mechanically connected to the sash wire and transmit a variable sash positioning voltage to the control unit. See the programming instruction, parameter P28 and P29.

The sash sensor in conjunction with a measured velocity in the sash opening will result in a 0...10V signal equal to 0...999 l/s on terminals 10 and 11 in the control unit.

Design

The Sensor consist of a multi-turn precision potentiometer with an attached wheel which is mounted on a spring loaded level and a metal bracket.

The potentiometer wheel press against the sash wire and turn the potentiometer with the sash movement.

Mounting

Place the sash sensor at the fume hood top with the wheel beneath the wire acc. to figure. Check that the wire is parallel and in-line with wheel.

Mark the surface of the fume hood at the mounting holes of the sensor bracket and drill the two holes with a \varnothing 4 mm bore.

Fasten the bracket using the attached screws.

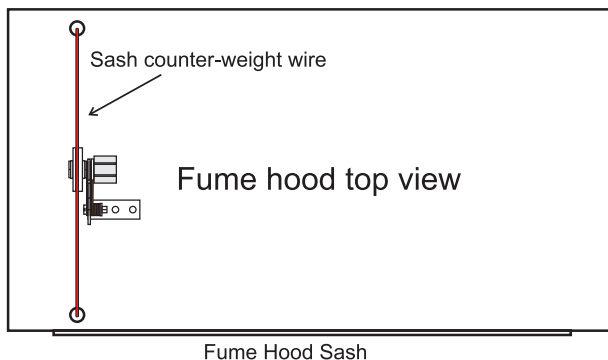

Sensor adjustment with closed Sash

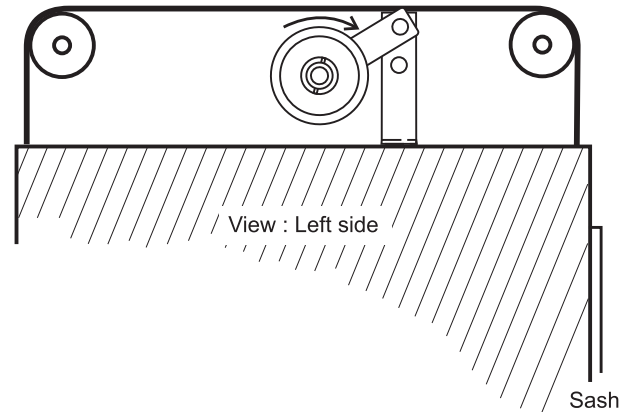

Close the sash and push down the sensor level to release the tension of the wire on the wheel. Turn the wheel fully clockwise until the potentiometer's mechanical stop and then back a quarter of a turn.

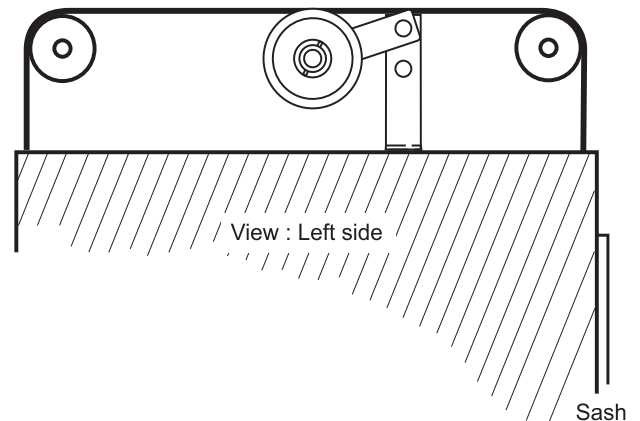

Release the wheel so it stops against the wire.
NOTE! Max mechanical sash movement is 100 cm. If this limit is exceeded, the sash sensor potentiometer setting will be reset with each full sash movement and lead to fault measurement. Contact Micatrone if larger sash movement is required than 100 cm. Connect the sensor electrical wires to the control unit, FHC, according to the connection diagram.

Technical data:

Max sash movement:	100 cm
Potentiometer,	
- Resistance:	10 kOhm
- No. of turns:	10
Mounting screws:	\varnothing 5,5 x 16mm
Distance between the sash wire and mounting surface:	55 mm +/- 10 mm

Electrical connection of potentiometer

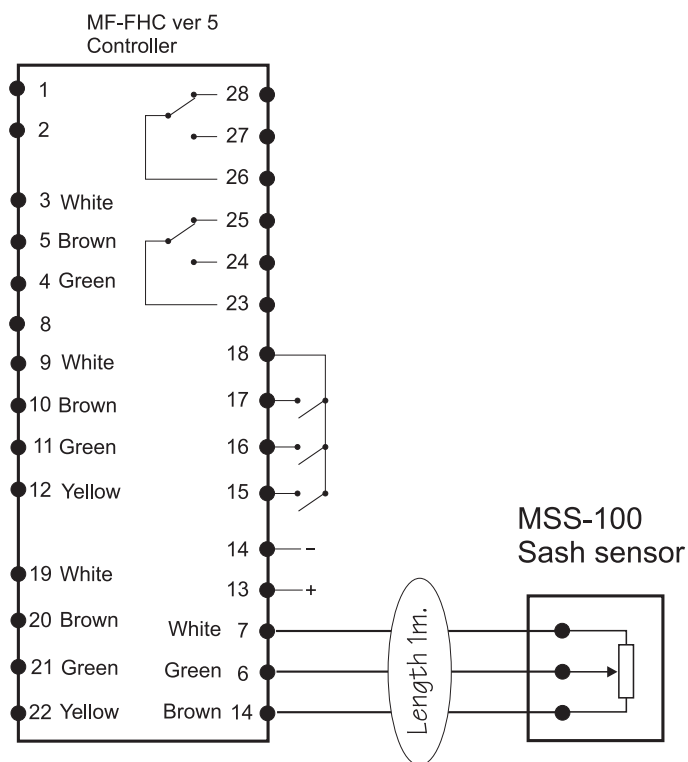

Dimensions

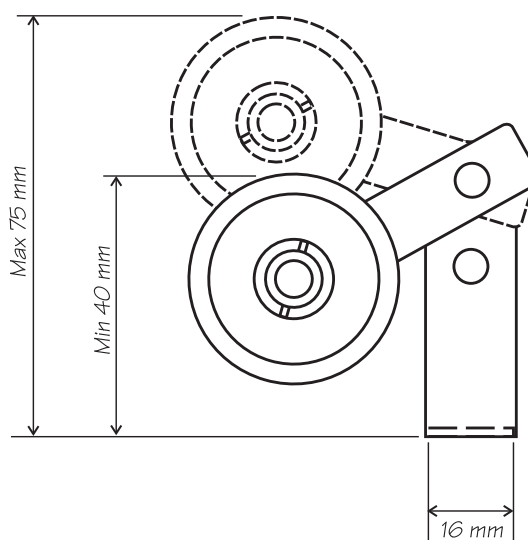
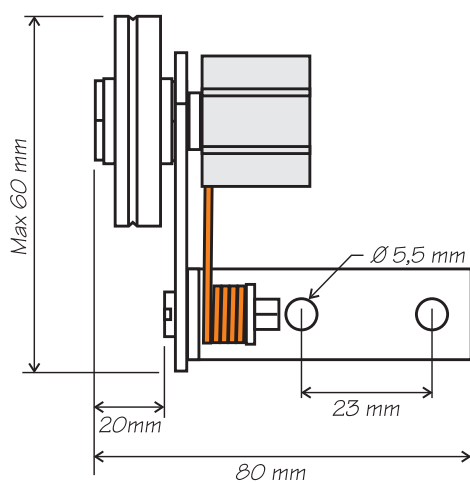

Micatrone AB
Åldermansvägen 3
SE-171 48 SOLNA
SWEDEN

Telefon: +46 8-470 25 00
Fax: +46 8-470 25 99
Internet: www.micatrone.se
E-mail: info@micatrone.se